





AT 510 ALUMINIUM-HAUSEINGANGSTÜR



EIGENSCHAFTEN

| | | |
|--|---------------------|--|
|  | Wärmedämmung | bis $U_b = 0,95 \text{ W/(m}^2\text{K)}$ |
|  | Schallschutz | bis 38 dB |
|  | Sicherheit | bis RC2 |
|  | Verriegelung | Mehrfach-Verriegelung |
|  | Bautiefe | 93 mm |

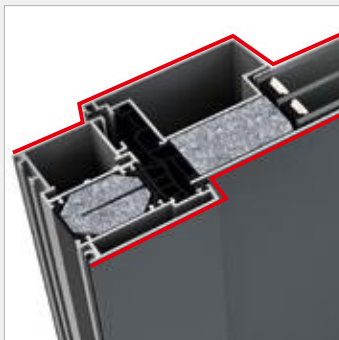

Innen profiliert
Außen kantig



Plattenaufbau mit Isolierglaskern
für ausgezeichnete Klimastabilität

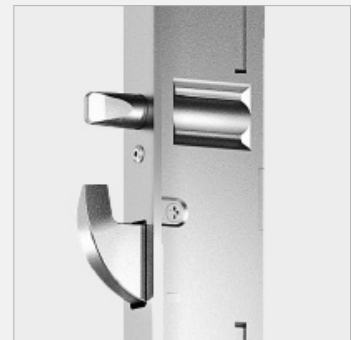

5-fach Verriegelung im Standard
für höchste Sicherheit

Schnitte

Schnitt unten

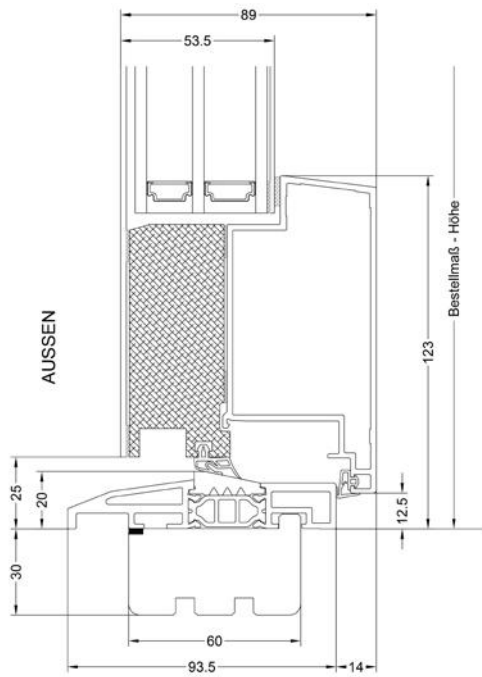

Schnitt seitlich, oben

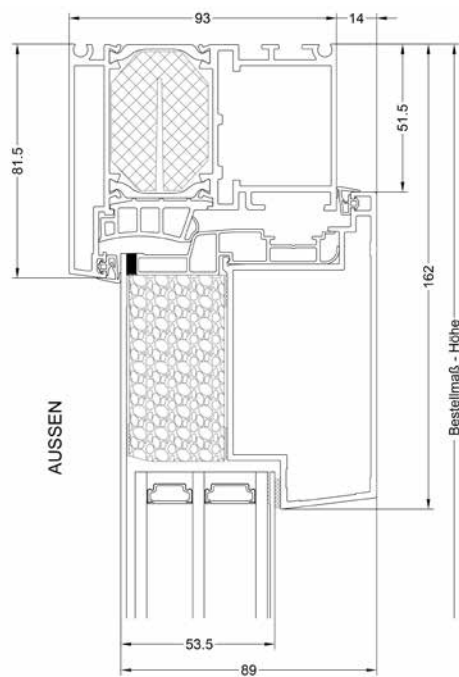

PG



PM



GD



GA

Weitere Modelle finden Sie im Türendesigner:

